

# Type 1+2 Lightning & Surge Protection For Photovoltaic Systems



When we are looking protecting an installation against over voltage, we have to give some consideration to external cables entering the building. PV installations will come in to this bracket. SPD's for PV systems are to protect the inverter and the fixed installation, therefore PV SPD's should be installed on the DC side of the PV system, before the inverter. These will always be Type 2 devices, unless the building has an external lightning protection system and the correct separation distance to BSEN 62305-3 has not been maintained, where you would install a Type 1 SPD.



Part No. LSPD PV600  
600V DC



Part No. LSPD PV1000  
1000V DC

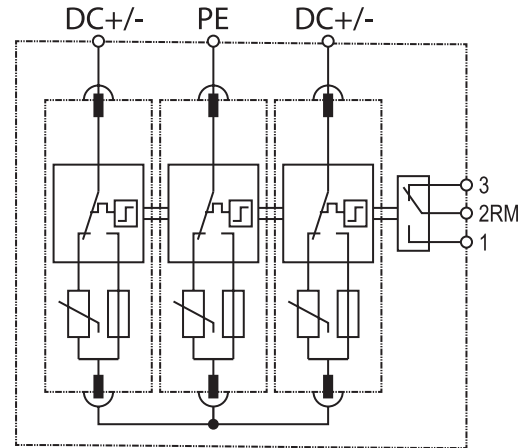

		LSPD PV600	LSPD PV1000
Classification according to BSEN61643-31		Type 1 + 2	
Maximum PV D.C voltage	$U_{cpv}$	$\leq 600$ V DC	$\leq 1000$ V DC
Maximum continuous operating voltage	$U_c$	625 V DC	1060 V DC
Short-circuit current rating	$I_{scpv}$	1000A	1000A
Nominal discharge current $I_n$ (8/20 $\mu$ s) kA	$I_n$	20kA	
Maximum discharge current $I_{max}$ (8/20 $\mu$ s) kA	$I_{max}$	40kA	
Voltage protection level at $I_n$	$U_p$	$\leq 2.5$ kV	$\leq 4.0$ kV
Voltage protection level at 5kA	$U_p$	$\leq 2.0$ kV	$\leq 3.5$ kV
Response time ns	$t_A$	<25ns	
Three way visual indication of status		Green - OK Red - Replace	
Tightening torque		4Nm	
Operating temperature		-40°C to +80°C	
Mounting on		35mm DIN rail	
Dimensions		W 54 x H 90 x D 66mm	
Recommended backup MCB/fuse DC type		32A to 63A	
Terminal capacity	Phase line Neutral line	2.5~35mm <sup>2</sup>	
	Earth line	4.0~35mm <sup>2</sup>	
	Signal line	1mm <sup>2</sup>	

